



Delta T 2000 120° x 20°

445-036 JULY 2005-REVISED JANUARY 2009

IMAGENEX MODEL 837 “Delta T” 2000 m OBSTACLE AVOIDANCE MULTIBEAM SONAR

APPLICATIONS:

- ROV, AUV, & UUV
- Offshore Oil & Gas
- Diving Support
- Surveying
- Search & Recovery
- Inspection
- Underwater Archaeology
- Scientific Research
- Harbour Surveillance

FEATURES:

- Programmable
- High speed
- High performance
- Lower cost
- Low power
- Simple set-up and installation
- Ethernet
- 5 m to 100 m range scales
- Integrated Video Capture and Display
- Built in GPS Track Plotter

The Imagenex Model 837 “Delta T” 2000 m is a high resolution multiple receiver sonar system run from a laptop or industrial PC computer. In this model, the acoustic array is designed to provide detection over a 120° x 20° field of view for imaging, moving object detection, and obstacle avoidance applications, and a 260 kHz acoustic frequency has been selected to provide sensitive detection at 100 m range. Image update rates are up to 20 times per second at short range and more than 5 times per second at 100 m range. The hard anodized aluminum housing provides a 2000 m depth rating for compatibility with ROV and AUV applications.

The provided software includes innovative digital signal processing to optimize data usage from all channels to achieve the best possible resolution at every point in the field of view. Recent advances in PC computing power have made it possible to transfer this data over a standard 10 BASE-T Ethernet connection and process it at resolutions equal to computer monitor resolution. Software is also available to store the data with a low power computer for processing into extremely high resolution images after uploading to a desktop PC.

The Delta T system has been designed from the ground up with the most advanced low power electronic components available to provide breakthroughs in system power consumption and package size. There is no expensive and bulky surface control box, so integration into ROV and AUV systems is simplified, and the cost is significantly less than other systems of similar capabilities.



Imagenex sonars: advancing underwater imaging capability for the everyday user.

Patent Pending

HARDWARE SPECIFICATIONS:	
FREQUENCY	260 kHz
TRANSDUCER BEAM WIDTH (nominal)	Receive: 120° (horizontal) x 20° (vertical) Transmit: 120° (horizontal) x 20° (vertical)
EFFECTIVE HORIZONTAL BEAM WIDTH	3°, 1.5°, 0.75°
BEAMS*	120, 240, 480
RANGE RESOLUTION	0.2% of range
MIN. DETECTABLE RANGE	0.5 m
MAX. OPERATING DEPTH	2000 m
FRAME RATE	Up to 20 fps
INTERFACE TO PC	Standard: 10 Mbps Ethernet (10 BASE-T) using TCP/IP Bit rate may vary if an Ethernet extender is in use.
MAX. CABLE LENGTH	Standard: 100 m on CAT5e Cable length may be increased up to ~9000 m using an Ethernet extender. Please enquire for more information.
CONNECTOR	Side mounted right angle, 8 conductor, wet mateable (Subconn MCBH-8M-SS)
POWER SUPPLY	22 – 50 VDC at less than 12 Watts
DIMENSIONS	See drawing
WEIGHT: In Air	3.9 kg (8.5 lbs)
In Water	1.7 kg (3.8 lbs)
MATERIALS	6061-T6 Aluminum, Epoxy, PVC, Stainless Steel connector
FINISH	Hard Anodize

* Data is acquired at full resolution every shot: processing the data for screen display on a PC can slow the system at highest number of beams. 120 beam mode is recommended for real time data acquisition. The data can then be played back at highest resolution (480 beam).

SOFTWARE SPECIFICATIONS:	DeltaT.exe
WINDOWS™ OPERATING SYSTEM	Windows™ XP, Vista
DISPLAY MODES	Sector, Linear, Perspective, Profile, Beam Test
PERSISTENCE (TRAIL)	1 – 300 seconds
RANGE SCALES	5 m, 10 m, 20 m, 30 m, 40 m, 50 m, 60 m, 80 m, 100 m
SECTOR SIZES	30°, 60°, 90°, 120°
FILE FORMAT	(filename).837
RECOMMENDED MINIMUM COMPUTER REQUIREMENTS:	2 GHz Pentium 4 256 MB RAM 20 GB Hard Disk 1024 x 768 screen resolution

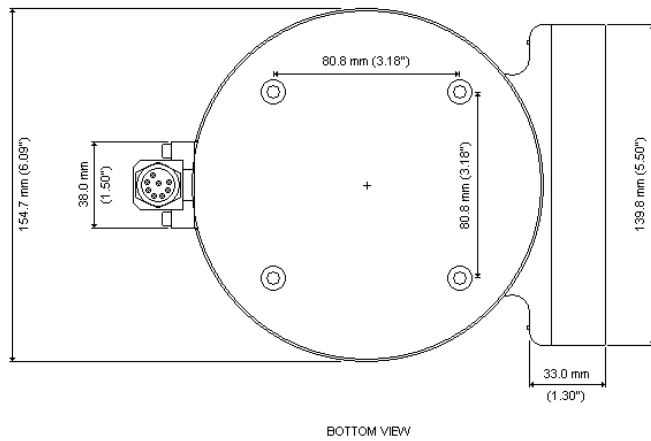
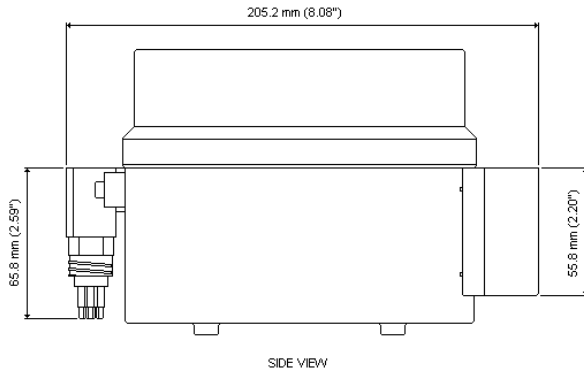
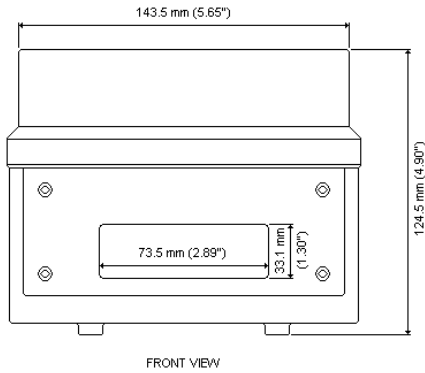

ORDERING INFORMATION:

2000 m UNIT	Standard	837-000-101
Straight Connector	Option	-009
IP Address*	Option	-020
675 kHz	Option	-022
External Trigger	Option	-023

*Note: Standard IP Address is 192.168.0.2
A different IP Address may be specified upon ordering.

Product and company names listed are trademarks or trade names of their respective companies.