

## IMAGENEX MODEL 878 "RGB" SIDESCAN SONAR

### APPLICATIONS:

- Underwater Archaeology
- Sunken Timber Recovery
- Search & Recovery
- Surveying
- Law Enforcement Work
- Scientific Research
- Environmental Survey

### FEATURES:

- Triple frequency
- High resolution 1000 data points per side
- 300 m depth rating
- Up to 1000 m (3000') total coverage
- 23 m (75') tow cable included
- LAN compatible
- Built-in track plotter
- Built-in internal GPS receiver
- Built-in orientation module

The Imagenex Model 878 "RGB" Sidescan Sonar is the next generation in high resolution sidescan sonar. The unit runs three simultaneous sonars on each side at different sound wavelengths, providing enhanced image clarity and now, for the first time, the ability to discriminate targets based on their acoustic "colour". Just as your eyes see in colour, the RGB sonar uses different wavelengths of sound, translating them directly to colours on the display of a Windows™ based laptop or desktop PC. To further enhance these unique sonar capabilities, the towfish is equipped with an echo sounder and a built-in orientation module as well as depth and temperature sensors.

The Model 878 system comes as a completely integrated package including towfish, cable, GPS enabled surface interface box, and Microsoft Windows™ based real time operation and data playback software, thus providing a complete, easy to use, but highly advanced acoustic bottom visualization system.



Patent Pending

<b>UNDERWATER HARDWARE SPECIFICATIONS:</b>	
<b>SIDECAN:</b>	
FREQUENCY	120 kHz / 260 kHz / 540 kHz
TRANSDUCER	Three transducers per side, tilted down 20°
TRANSDUCER BEAM WIDTH	1° x 60°
RANGE RESOLUTION	Range scale ÷ 1000
<b>ECHO SOUNDER:</b>	
FREQUENCY	200 kHz
TRANSDUCER	Conical
TRANSDUCER BEAM WIDTH	10°
RANGE RESOLUTION	Range scale ÷ 1000
<b>ORIENTATION MODULE (accuracies):</b>	
PITCH & ROLL	± 0.1° typical
HEADING	± 1.0° typical
DEPTH	± 0.5% of FS typical
TEMPERATURE	± 0.5°C typical
MAX. OPERATING DEPTH	300 m (~1000')
MAX. CABLE LENGTH	1000 m using built-in Ethernet extender
INTERFACE	Up to 2.3 Mbps Ethernet (10 BASE-T) using TCP/IP
CONNECTOR	Wet mateable (Impulse MCBH-4-MP)
POWER SUPPLY	40 – 55 VDC at less than 15 Watts, supplied from Surface Interface Box
DIMENSIONS	See drawing
WEIGHT: In Air	~75 lbs
In Water	~40 lbs
MATERIALS	6061-T6 Aluminum, PVC, 300 Series Stainless Steel, Polyurethane & Zinc
FINISH	Hard anodized

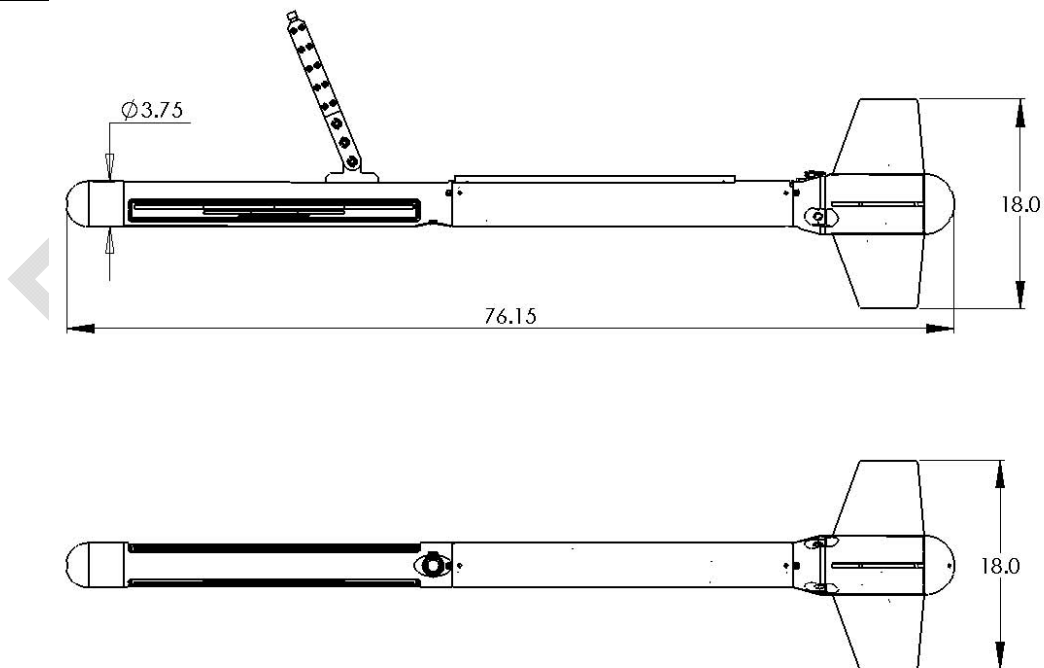

<b>SOFTWARE SPECIFICATIONS:</b>	<b>RGB SideScan.exe</b>
<b>WINDOWS™ OPERATING SYSTEM</b>	Windows™ XP, Vista
<b>ZOOM MODES</b>	1x, 2x, 3x, 4x, and 5x dynamically moveable
<b>RANGE SCALES</b>	
<b>SIDESCAN:</b>	
<b>RGB MODE:</b>	10 m, 20 m, 30 m, 40 m, 50 m, 60 m, 80 m, 100 m, 125 m
<b>120 kHz:</b>	10 m, 20 m, 30 m, 40 m, 50 m, 60 m, 80 m, 100 m, 125 m, 150 m, 200 m, 250 m, 300 m, 400 m, and 500 m
<b>260 kHz:</b>	10 m, 20 m, 30 m, 40 m, 50 m, 60 m, 80 m, 100 m, 125 m, 150 m, 200 m, and 250 m
<b>540 kHz:</b>	10 m, 20 m, 30 m, 40 m, 50 m, 60 m, 80 m, 100 m, 125 m
<b>ECHO SOUNDER:</b>	10 m, 20 m, 30 m, 40 m, 50 m, 60 m, 80 m, 100 m, 125 m, 150 m, 200 m
<b>FILE FORMAT</b>	(filename).RGB
<b>GPS INPUT (4800, N, 8, 1) NMEA 0183 FORMATS:</b>	GLL and VTG; GGA and VTG; RMC
<b>RECOMMENDED MINIMUM COMPUTER REQUIREMENTS:</b>	800 MHz Pentium 3 256 MB RAM 2 GB Hard Disk 1024 x 768 x 256 colour graphics

<b>ORDERING INFORMATION:</b>		
<b>300 m unit w / 23 m tow cable</b>	Standard	878-000-150
<b>Surface Interface Box</b>	Standard	878-000-001
60 m (200') Sidescan tow cable	Option	-021
100 m (330') Sidescan tow cable	Option	-033

Product and company names listed are trademarks or trade names of their respective companies.