



IMAGENEX MODEL 852 ULTRA-MINIATURE SCANNING SONAR

APPLICATIONS:

- ROV Navigation
- Diving Support
- Inspection
- Search & Recovery

FEATURES:

- Ultra-miniature size is ideal for mounting on today's micro ROV's
- Continuous rotation
- Low cost
- Direct connection to laptop computer

The Model 852 Digital Imaging Sonar was designed for use with the smallest of ROV's. For maximum flexibility, this is a design with a fluid filled front end and a pressure housing for the electronics. The unit requires approximately 2.5 Watts from 24 VDC, or optional 48 VDC. Serial communication is utilized, RS-485 or RS-232 at 115.2 kbps. This unit will scan a maximum of 360° with a maximum range of 50 meters. The total weight in water is less than 0.2 kg (0.4 lbs).



HARDWARE SPECIFICATIONS:	
FREQUENCY	675 / 850 kHz
TRANSDUCER	Imaging type, fan beam, fluid compensated
TRANSDUCER BEAM WIDTH	2.5° x 22°
TRANSMIT PULSE LENGTH	100 microseconds
RANGE RESOLUTION	20 mm
MIN. DETECTABLE RANGE	150 mm
MAX. OPERATING DEPTH	300 m
MAX. CABLE LENGTH	1000 m on typical twisted shielded pair
INTERFACE	RS-485 @ 115.2 kbps (RS-232 optional)
CONNECTOR	IE55-1206-BCR Penetrator
POWER SUPPLY	22 – 30 VDC at less than 2.5 Watts Optional 40 – 56 VDC
DIMENSIONS	See drawing
WEIGHT: In Air	316 g (0.7 lbs)
In Water	with 24" pigtail 150 g (0.3 lbs)
MATERIALS	6061-T6 Aluminum & Polyurethane
FINISH	Hard Anodize

SOFTWARE SPECIFICATIONS:	Win852.exe
WINDOWS™ OPERATING SYSTEM	Windows™ 95, 98, Me, NT, 2000, XP
MODES	Polar, Sector, and Sidescan
RANGE SCALES	5 m, 10 m, 20 m, 30 m, 40 m, 50 m
SECTOR SIZE:	
SECTOR MODE	0° – 180°, 18° increments
POLAR MODE	360°, continuous
STEP SIZES	Normal (3°), Fast (6°)
GRID TYPE	Polar
EXTERNAL INPUT	Depth, Heading, Turns
FILE FORMAT	(filename).852
RECOMMENDED MINIMUM COMPUTER REQUIREMENTS:	100 MHz Pentium 16 MB RAM 1 GB Hard Disk 800 x 600 x 256 colour graphics

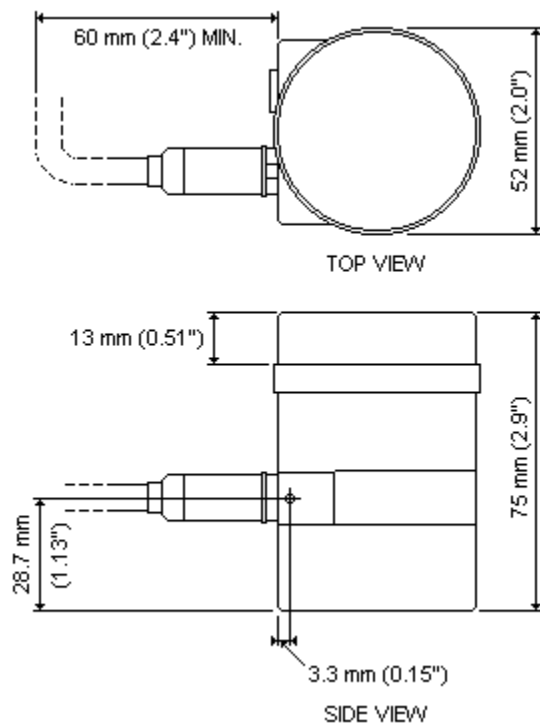

ORDERING INFORMATION:		
300 m UNIT	Standard	852-000-100
RS-232	Option	-006
40 – 56 VDC	Option	-013

Product and company names listed are trademarks or trade names of their respective companies.